

CAD FILE:

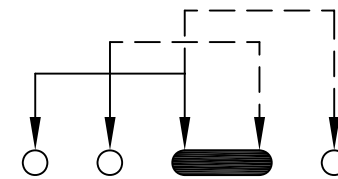

SCHMATIC (SHORTING)

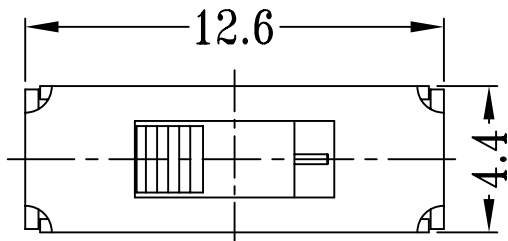
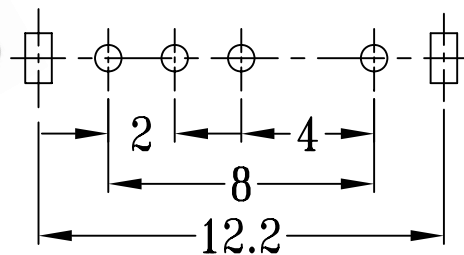
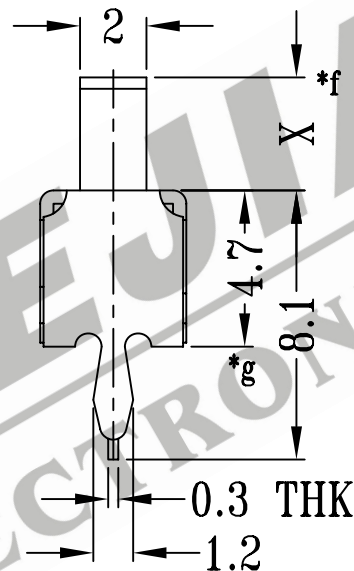
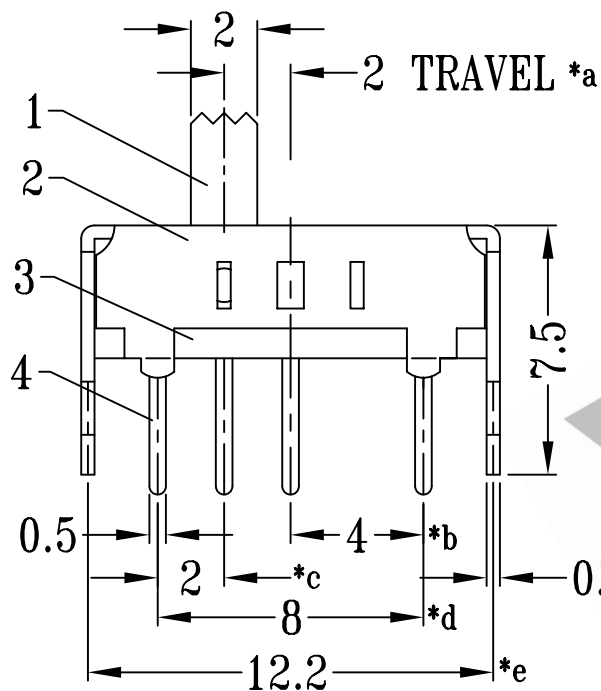

P.C.B LAYOUT

注:带"*"表示关键尺寸(7个)

				TOLERANCE UNLESS SPECIFIED		SHENZHEN XIEJIA ELECTRONICS CO.,LTD.							
				WITHIN: 1.5±0.1mm OVER: 1.5±0.2mm		ISSUE	DATE	DESCRIPTIONS OF REVISION		APPD.			
8						TITLE : VERTICAL SLIDE SWITCH				UNIT : mm	DRWG NO.: XJ-DR-SS13D01-00		
7						MODEL: SS-13D01				SCALE: 4:1	DWN.	ZHOUYU	2005-5-14
6	SPRING PLATE	STAINLESS STEEL	2	NATURAL				CHK'D	FANGYING	2005-5-14			
5	CONTACT CLIP	PBS	1	Ag CLAD				SAPPD.	KANGXINAN	2005-5-14			
4	TERMINAL	BRASS STRIP	4	Ag PLATED	ALL MATERIALS MUST BE COMPLIANT TO ROHS								
3	BASE	PHENOLIC RESIN	1	NATURAL									
2	FRAME	STEEL STRIP	1	Ni PLATED									
1	KNOB	POM	1	BLACK									
NO.	PARTS	MATERIALS	Q'TY	FINISH									